

30Eggs



SIDE VIEW



QUALITY



FRONT VIEW



TOP VIEW



30Eggs



MATERIAL PET
COLOUR GLASSCLEAR/MILKY
CALIBER 53g - 73g



BOX DIMENSIONS

800 x 300 x 505 mm (L x W x H)
 31.50" x 11.81" x 19.88" (L x W x H)

| | |
|------------------|-------|
| Pack Weight (kg) | 0,04 |
| Box Weight (kg) | 15,60 |
| Volume Box (m³) | 0,12 |



STORAGE

max. 1 year
 max. +40°C / min. +10°C
 Do NOT expose to sunlight

Pallet Dimensions:
 mm > 1.200 x 800 x 2.650
 inches > 47.24" x 31.50" x 104.33"

Layer structure: 2 Boxes/Layer



PACK DIMENSIONS

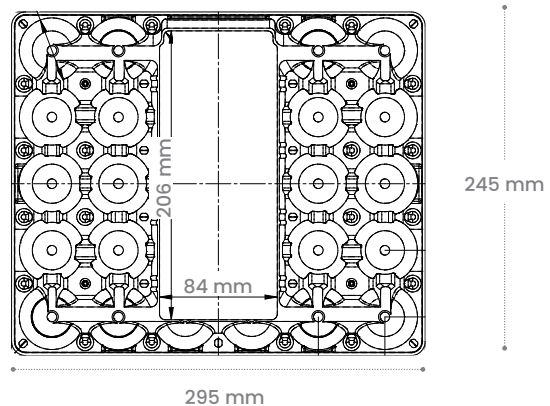
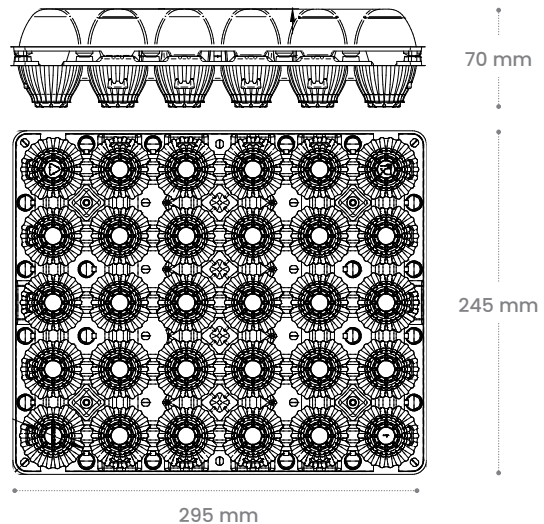

TRUCK LOADING

| | |
|---------------|--------------------------------------|
| Pieces/Box | 390 |
| Box/Pallet | 18 |
| Pieces/Pallet | 7.020 (3.510 base & 3.510 top) |
| Pallets/Truck | 32 (16 base & 16 top) |
| Pieces/Truck | 224.640 (112.320 base & 112.320 top) |



CONTAINER LOADING

| | Pieces |
|-------|---|
| 20" | 76.440 sets (38.220 base & 38.220 top) |
| 40" | 163.800 sets (81.900 base & 81.900 top) |
| 40 HC | 204.360 sets (102.180 base & 102.180 top) |



MACHINE SETUP

MOBA

| L | G | J | II | I2 |
|----|----|---|----|----|
| 22 | 23 | 5 | 5 | 45 |



DECORATION

✓ Label

Products can be customized by the attachment of labels, our graphics department is available for the realization of the necessary materials.



CERTIFIED QUALITY

Celplast meets the global BRCGS standard which guarantees the quality and safety of the food products that it brings to the market. The BRCGS standard is periodically examined through internal controls, which ensure that a high level of product is maintained.